

YSI Environmental

Pure
Data for a
Healthy
Planet.™



YSI 550A
Dissolved Oxygen Instrument

Operations
Manual

CONTENTS

CONTENTS.....	iii
GENERAL DESCRIPTION.....	1
WARRANTY	2
FEATURES OF THE YSI 550A	3
PRINCIPLES OF OPERATION.....	5
PREPARING THE PROBE.....	5
DISSOLVED OXYGEN CALIBRATION	6
SALINITY COMPENSATION CALIBRATION	7
PROBE OPERATION	8
PROBE ELECTRODE MAINTENANCE	9
ACCESSORIES/REPLACEMENT PARTS	10
SPECIFICATIONS	11
TROUBLESHOOTING.....	12
CONTACT INFORMATION	13
REQUIRED NOTICE.....	14

GENERAL DESCRIPTION

The YSI 550A Handheld Dissolved Oxygen Instrument is a rugged, microprocessor based, digital instrument with a field-replaceable YSI dissolved oxygen probe. The YSI 550A DO Instrument is impact-resistant and waterproof.

The YSI 550A DO Instrument is designed for field use and is available with cable lengths of 12, 25, 50, or 100 feet (3.5, 7.5, 15, 30.5 meters). The body of the probe has been manufactured with stainless steel to add rugged durability and sinking weight. The large Liquid Crystal Display (LCD) is easy to read and is equipped with a backlight for use in dark or poorly lighted areas.

The YSI 550A DO Instrument can be easily calibrated with the press of a few keys. Additionally, the instrument's microprocessor performs a self-diagnostic routine each time the instrument is turned on. The self-diagnostic routine provides you with useful information about the function of the instrument circuitry and the quality of the readings you obtain.

The system displays temperature in either °C or °F and dissolved oxygen in either mg/L (milligrams per liter) or % air saturation. The system requires only a single calibration regardless of which dissolved oxygen display is used, and will calibrate in either mode. Salinity compensation values can be changed at any time without performing a new calibration.

A detachable calibration chamber is mounted to the back of the instrument. A small sponge in the chamber can be moistened to provide a water saturated air environment that is ideal for air calibration. This chamber is also designed for transporting and storing the probe. When the probe is stored in the chamber, the moist environment will prolong effective membrane performance and probe life.

The YSI 550A DO Instrument is powered by 4 C-size alkaline batteries. A new set of alkaline batteries will provide approximately 2000 hours of continuous operation. If the backlight is used often, batteries will be depleted faster.

The YSI 550A case is waterproof with an IP-67 rating. The instrument is 100% corrosion proof and can be operated in a wet environment without damage to the instrument.

INITIAL INSPECTION

When you unpack your new YSI 550A DO Handheld Instrument for the first time, check the packing list to make sure you have received everything. If there is anything missing or damaged, call the dealer from whom you purchased the YSI 550A. If you do not know which authorized dealer sold the system to you, call YSI Customer Service at 800-897-4151 or 937-767-7241.

WARRANTY REGISTRATION

Please complete the Product Registration on the YSI website at www.ysi.com. If you are not online, you may complete the Warranty Card included with your instrument and return it to YSI Incorporated. Your purchase of this quality instrument will then be recorded in YSI's customer database. Once your purchase is recorded, you will receive prompt, efficient service in the event any part of your YSI 550A DO Instrument should ever need repair.

WARRANTY

The YSI 550A DO Instrument is warranted for three years from date of purchase by the end user against defects in materials and workmanship. YSI 550A DO probes and cables are warranted for one year from date of purchase by the end user against defects in material and workmanship. Within the warranty period, YSI will repair or replace, at its sole discretion, free of charge, any product that YSI determines to be covered by this warranty.

To exercise this warranty, write or call your local YSI representative, or contact YSI Customer Service in Yellow Springs, Ohio. Send the product and proof of purchase, transportation prepaid, to the Authorized Service Center selected by YSI. Repair or replacement will be made and the product returned, transportation prepaid. Repaired or replaced products are warranted for the balance of the original warranty period, or at least 90 days from date of repair or replacement.

Limitation of Warranty

This Warranty does not apply to any YSI product damage or failure caused by (i) failure to install, operate or use the product in accordance with YSI's written instructions, (ii) abuse or misuse of the product, (iii) failure to maintain the product in accordance with YSI's written instructions or standard industry procedure, (iv) any improper repairs to the product, (v) use by you of defective or improper components or parts in servicing or repairing the product, or (vi) modification of the product in any way not expressly authorized by YSI.

THIS WARRANTY IS IN LIEU OF ALL OTHER WARRANTIES, EXPRESSED OR IMPLIED, INCLUDING ANY WARRANTY OF MERCHANTABILITY OR FITNESS FOR A PARTICULAR PURPOSE. YSI's LIABILITY UNDER THIS WARRANTY IS LIMITED TO REPAIR OR REPLACEMENT OF THE PRODUCT, AND THIS SHALL BE YOUR SOLE AND EXCLUSIVE REMEDY FOR ANY DEFECTIVE PRODUCT COVERED BY THIS WARRANTY. IN NO EVENT SHALL YSI BE LIABLE FOR ANY SPECIAL, INDIRECT, INCIDENTAL OR CONSEQUENTIAL DAMAGES RESULTING FROM ANY DEFECTIVE PRODUCT COVERED BY THIS WARRANTY.

FEATURES OF THE YSI 550A

KEYPAD

 Powers the unit on or off. The instrument will activate all segments of the display for a few seconds, and then will show a self-test procedure for several more seconds. During this power on self-test sequence, it is normal for error messages to appear and disappear. If the instrument were to detect a problem, a **continuous** error message would be displayed.

 Turns the display backlight on or off. The light will turn off automatically after two minutes of non-use.

Mode During DO calibration it allows the user to select between % and mg/L. After selection, it may be pressed several times to exit back to measurement mode without completing the calibration. During measurement, it switches the instrument display between DO %, DO mg/L, and salinity calibration.

▲ and ▼ Increases or decreases the value during calibrations.

▼ and Mode Press at the same time to switch the temperature units between Fahrenheit (F) and Celsius (C).

▲ and Mode Press at the same time to increase or decrease the resolution of the instrument in mg/L or % measurement mode.

BATTERIES

The YSI 550A DO Instrument is powered by 4 C-size alkaline batteries. A new set of alkaline batteries will provide approximately 2000 hours of continuous operation. When batteries need to be replaced, the LCD will display a "**LO BAT**" message. When the message first appears, the instrument will have approximately 50 hours of life left, provided the back light is not used.

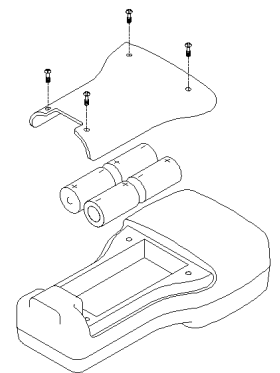

INSTRUMENT CASE

The waterproof instrument case is sealed at the factory and is not to be opened, except by authorized service technicians.

Caution: Do not attempt to separate the two halves of the instrument case as this may damage the instrument, break the waterproof seal, and will void the manufacturer's warranty.

CALIBRATION/STORAGE CHAMBER

The YSI 550A DO Instrument has a convenient calibration/storage chamber that can be attached to the instrument's back. The calibration chamber can be used from either side of the instrument, by moving the rubber stopper to either end.

If you look into the chamber, you should notice a small round sponge in the bottom. Carefully put 3 to 6 drops of clean water into the sponge. Turn the instrument over and allow any excess water to drain out of the chamber. The wet sponge creates a 100% water saturated air environment for the probe. This environment is ideal for dissolved oxygen calibration and for storage of the probe during transport and non-use.

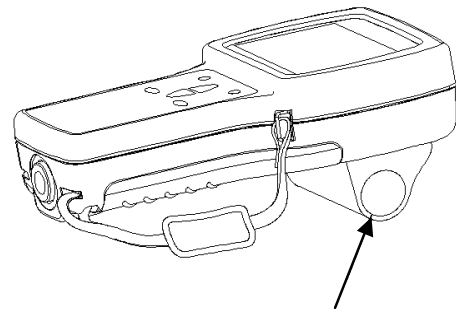

CALIBRATION CHAMBER

The YSI 550A DO Instrument's storage chamber can be conveniently used from either side of the instrument.

1. Remove the chamber from the instrument by unscrewing the two screws.
2. Remove the rubber stopper from the chamber by pulling the "tail" free of the small hole on the chamber.
3. Re-attached the rubber stopper to the storage chamber by threading the "tail" through the opposite small hole on the chamber.
4. Re-attached the storage chamber to the instrument using the two screws.

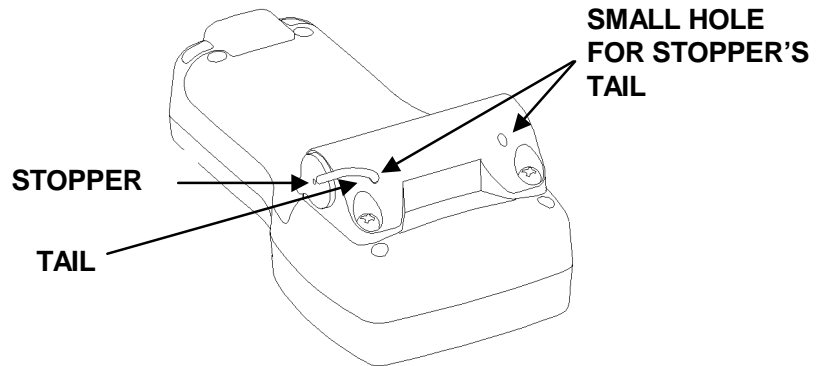

HAND STRAP

The hand strap is designed to allow comfortable operation of the YSI 550A DO Instrument with minimum effort. If the hand strap is adjusted correctly, it is unlikely that the instrument will be dropped or bumped from your hand. The hand strap can be conveniently used from either side of the instrument.

To switch the hand strap from one side to the other:

1. Pull the two velcro strips apart.
2. Pull the strap free of the upper and lower hooks.
3. Feed the strap through the hooks on the other side of the instrument.
4. Adjust the strap length so that your hand is snugly held in place.
5. Press the two velcro strips back together.

PRINCIPLES OF OPERATION

The sensor consists of a silver body as the anode and a circular gold cathode embedded in the end. In operation, this end of the sensor is filled with a solution of electrolyte containing a small amount of surfactant to improve wetting action.

A thin semi-permeable membrane, stretched over the sensor, isolates the electrodes from the environment, while allowing gases to enter. When a polarizing voltage is applied to the sensor electrodes oxygen that has passed through the membrane reacts at the cathode causing a current to flow.

The membrane passes oxygen at a rate proportional to the pressure difference across it. Since oxygen is rapidly consumed at the cathode, it can be assumed that the oxygen pressure inside the membrane is zero. Hence, the force causing the oxygen to diffuse through the membrane is proportional to the partial pressure of oxygen outside the membrane. As the oxygen partial pressure varies, so does the oxygen diffusion through the membrane. This causes the probe current to change proportionally.

PREPARING THE PROBE

MEMBRANE CAP INSTALLATION

The YSI 550A DO probe is shipped with a dry, protective membrane. Before using the instrument for the first time, remove the protective cap and replace it with a new one following these instructions:

1. Remove the probe sensor guard to access the probe tip.
2. Unscrew and remove the old membrane cap and discard.
3. Thoroughly rinse the sensor tip with distilled or DI water.
4. Fill a new membrane cap with O₂ probe solution that has been prepared according to the directions on the bottle. Be very careful not to touch the membrane surface. Lightly tap the side of the membrane cap to release bubbles that may be trapped.
5. Thread the membrane cap onto the probe. It is normal for a small amount of electrolyte to overflow.
6. Replace the probe sensor guard.

MEMBRANE MAINTENANCE

Additional membrane changes will be required over time. The average replacement interval is 4 to 8 weeks, although they may last longer if kept clean. To clean the membrane, use a lint-free cloth, such as a Kimwipe, and rubbing alcohol to gently remove the contamination. In harsh environments, such as wastewater, membrane replacements may be required every 2 to 4 weeks.

DISSOLVED OXYGEN CALIBRATION

Dissolved oxygen calibration must be done in an environment with known oxygen content. The YSI 550A DO Instrument can be calibrated in either mg/L or % saturation. Sections below include instructions on how to calibrate in either mode.

BEFORE YOU CALIBRATE

To accurately calibrate the YSI 550A, you will need to know the following information:

- The approximate salinity of the water you will be analyzing. Fresh water has a salinity of approximately zero. Seawater has a salinity of approximately 35 parts per thousand (ppt). If you are uncertain what the salinity of the sample water is, use a YSI 30 Salinity-Conductivity-Temperature instrument to determine a salinity value.
- For calibration in % saturation mode, the approximate altitude (in feet) of the region where you are located is required. This information can be obtained over the internet or from a local airport or weather station. To convert from meters to feet, divide by 0.3048.

For best results:

- Check calibration with each use and recalibrate as necessary to prevent drift. Dissolved oxygen readings are only as good as the calibration.
- Calibrate at a temperature within $\pm 10^{\circ}\text{C}$ of the sample temperature.

CALIBRATION IN % SATURATION

1. Ensure that the sponge inside the instrument's calibration chamber is moist. Insert the probe into the calibration chamber.
2. Turn the instrument on. Allow it to warm up and readings to stabilize for about 15-20 minutes.
3. Press and release both the **UP ARROW** and **DOWN ARROW** keys at the same time to enter the calibration menu.
4. Press the **Mode** key until “%” is displayed on the right side of the screen for oxygen units. Press **ENTER**.
5. The LCD will prompt you to enter the local altitude in hundreds of feet. Use the arrow keys to increase or decrease the altitude. When the proper altitude appears on the LCD, press the **ENTER** key.

EXAMPLE: Entering the number 12 here indicates 1200 feet.

6. **CAL** will now display in the lower left corner of the screen, the calibration value in the lower right corner and the current DO reading (before calibration) will be the main display. Once the current DO reading is stable, press the **ENTER** button.
7. The LCD will prompt you to enter the approximate salinity of the water you are about to analyze. You can enter any number from 0 to 70 parts per thousand (PPT) of salinity. Use the arrow keys to increase or decrease the salinity setting. When the correct salinity appears on the LCD, press the **ENTER** key. The instrument will return to normal operation.

CALIBRATION IN MG/L

1. Turn the instrument on. Allow it to warm up and readings to stabilize for about 15-20 minutes.
2. Place the probe in a solution with a known mg/L reading. Continuously stir or move the probe through the sample at a rate of at least 1/2 foot per second (16cm per second) during the entire calibration process.
3. Press and release both the **UP ARROW** and **DOWN ARROW** keys at the same time to enter the calibration menu.
4. Press the **Mode** key until “mg/L” is displayed on the right side of the screen for oxygen units. Press **ENTER**.
5. **CAL** will now display in the lower left corner of the screen and the current DO reading (before calibration) will be on the main display. Once the current DO reading is stable, use the up and down arrow keys to select the mg/L value of the known solution, then press the **ENTER** button.
6. The LCD will prompt you to enter the approximate salinity of the water you are about to analyze. Enter any number from 0 to 70 parts per thousand (PPT) of salinity. Use the arrow keys to increase or decrease the salinity setting. When the correct salinity appears on the, press the **ENTER** key. The instrument will return to normal operation.

SALINITY COMPENSATION CALIBRATION

1. Press the **Mode** key until salinity calibration is displayed on the screen.
2. Use the **UP ARROW** and **DOWN ARROW** keys to adjust the salinity value to that of the samples you will be measuring, 0-70 ppt.
3. Press the **ENTER** key to save the calibration.
4. Press **Mode** to return to dissolved oxygen measurement

PROBE OPERATION

NOTE: The YSI 550A DO Instrument should not be used in a purpose other than that specified by YSI Incorporated. See **Warranty** for details.

STIRRING

It is important to recognize that a very small amount of oxygen dissolved in the sample is consumed during probe operation. It is therefore essential that the sample be continuously stirred at the sensor tip. If stagnation occurs, measurements will appear artificially low.

Stirring may be accomplished by mechanically moving the sample around the probe tip, or by moving the probe through the sample. The YSI Model 550A has a flow dependence of <25%. The rate of stirring required is 1/2 foot per second (16cm per second).

MEASUREMENT PROCEDURE

1. Insert the probe into the sample to be measured.
2. Continuously stir or move the probe through the sample.
3. Allow temperature and dissolved oxygen readings to stabilize.
4. Observe/Record readings.
5. If possible, rinse the probe with clean water after each use.

PRECAUTIONS

1. Membranes last longer if properly installed and regularly maintained. Erratic readings can result from loose, wrinkled, damaged, or fouled membranes, large (more than 1/8" diameter) air bubbles in the electrolyte reservoir, or membrane coating by oxygen consuming (e.g. bacteria) or oxygen producing (e.g. algae) organisms. If unstable readings or membrane damage occurs, replace both the membrane cap and electrolyte solution.
2. Chlorine, sulfur dioxide, nitric oxide, and nitrous oxide can affect readings by behaving like oxygen at the probe.
3. Avoid substances such as acids, caustics, and strong solvents, which may damage probe materials. Probe materials include the PE membrane, acrylic plastic, EPR rubber, stainless steel, epoxy, polyetherimide and the PVC cable covering.
4. Always store the probe in the calibration/storage chamber with the moistened sponge.

PROBE ELECTRODE MAINTENANCE

SILVER ANODE

After extended use, a thick layer of AgCl builds up on the silver anode reducing the sensitivity of the sensor. The anode must be cleaned to remove this layer and restore proper performance. The cleaning can be chemical or mechanical:

- **Chemical cleaning:** Remove the membrane cap and rinse the electrodes deionized or distilled water. Soak the entire anode section in a 14% ammonium hydroxide solution for 2 to 3 minutes (or a 3% solution may be used and soaked overnight for 8-12 hours). Rinse heavily in cool tap water followed by a thorough rinsing with distilled or deionized water. The anode should then be thoroughly wiped with a wet paper towel to remove the residual layer from the anode.

Warning: Chemical cleaning should be performed on an as-needed basis, and no more often than once a year (or once per six months in wastewater environments). When readings appear unstable or the instrument will not calibrate, first attempt a membrane change and recalibrate. If a new membrane does not resolve the problem, then proceed with the chemical cleaning.

- **Mechanical cleaning:** Sand off the dark layer from the silver anode with 400 grit wet/dry sandpaper. Wrap the wet sandpaper around the anode and twist the probe. Rinse the anode with clean water after sanding, and wipe thoroughly with a wet paper towel.

GOLD CATHODE

For correct probe operation, the gold cathode must be textured properly. It can become tarnished or plated with silver after extended use. The gold cathode can be cleaned by using the YSI 5238 Probe Reconditioning Kit or 400 grit wet/dry sandpaper. Never use chemicals or abrasives not recommended or supplied by YSI.

Using the sanding paper provided in the YSI 5238 Probe Reconditioning Kit, wet sand the gold with a twisting motion about 3 times or until all silver deposits are removed and the gold appears to have a matte finish. If the cathode remains tarnished, return the probe for service. Wipe the gold cathode thoroughly with a wet paper towel before putting on a new membrane cap.

REPLACEMENT OF THE DO ELECTRODES

Should replacement of the DO Electrodes be required, the user may purchase a YSI 559 Replaceable DO Module Kit. The kit includes an instruction sheet, DO sensor module, set screw, and hex key wrench.

1. Remove probe guard.
2. **IMPORTANT:** Thoroughly dry the sensor so that no water enters the probe port when the sensor is removed.
3. Insert the long end of the hex key wrench into the small hole in the side of the DO sensor. Turn the wrench counter clockwise until the sensor is released.
4. Pull the DO sensor out of the probe. The DO sensor is keyed, or has a flat side, so that it can not be removed or inserted improperly.
5. Make sure that the inside of the connector and the o-ring of the sensor are clean and dry, with no contaminants, such as grease, dirt, or hair. Insert the new sensor.
6. Use the hex key wrench to tighten the screw, making sure that the screw does not stick out on either side of the DO sensor module. Also, if the hex screw was removed completely, make sure that it is not cross-threaded when replaced.
7. The YSI 559 DO module is shipped with a dry, protective membrane. Before using for the first time, remove the protective cap and replace it with a new one following the instructions for **Membrane Cap Installation**.

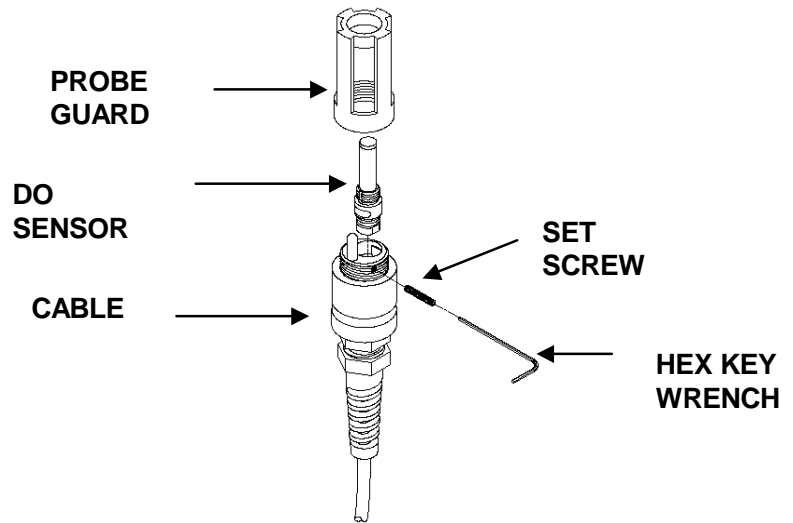

ACCESSORIES/REPLACEMENT PARTS

The following parts and accessories are available from YSI or any YSI Authorized Dealer.

YSI Model Number	Description
5908	Membrane Kit, 1.25 mil PE, 6 caps and bottle of electrolyte solution
559	Replaceable DO Module
5238	Probe Reconditioning Kit, 10 sanding discs (400 grit) and sanding tool
5065	Form-Fitted Cover with Shoulder Strap
614	Ultra Clamp, C-Clamp Mount
4654	Tripod
5085	Hands Free Harness
5050	Small, Hard-sided Carrying Case, Foam-lined
5060	Small, Soft-sided Carrying Case, Precut Foam Interior
5080	Small, Hard-sided, Pelican Carrying Case, Precut Foam Interior

SPECIFICATIONS

Display	Resolution	Range	Accuracy
Dissolved O ₂ mg/L	0.01 mg/L or 0.1 mg/L, user selectable	0 to 20 mg/L	± 0.3 mg/L or ± 2% of reading, whichever is greater
		20 to 50 mg/L	± 6% of reading
Dissolved O ₂ %	0.1% or 1%, user selectable	0 to 200%	± 2% air sat or ± 2% of reading, whichever is greater
		200 to 500%	± 6% of reading
Temperature °C	0.1 °C	-5 to +45 °C	± 0.3 °C
Temperature °F	0.1 °F	23 to 113 °F	± 0.6 °F

Medium:	Fresh, sea or polluted water
Dissolved Oxygen Sensor:	Steady-state polarographic
Dissolved Oxygen Probe:	Field-replaceable module
Dissolved Oxygen Response Time:	95% of end value in 9 seconds
Temperature Units:	Celsius or Fahrenheit, user selectable
Parameter Compensation:	Automatic temperature compensation for dissolved oxygen Automatic salinity compensation (0-70 ppt) for dissolved oxygen Altitude compensation for dissolved oxygen percent calibration
Size:	4.7 in. width; 9 in. length (11.9 cm x 22.9 cm)
Weight with Batteries:	2 lb. (0.91 kg)
Power:	4 alkaline C-cells
Battery life:	Over 2000 hours at 25°C (77°F)
Cables:	12, 25, 50, and 100-foot lengths (3.5, 7.5, 15, 30.5 meter lengths)
Other Features:	Waterproof to IP-67 High-impact resistance Push-button calibration Built-in calibration chamber Large back-lit display Low battery indicator on display Manual salinity input CE-compliance

TROUBLESHOOTING

NOTE: An error displayed briefly during the first few seconds after turning the instrument on does NOT indicate a problem.

SYMPTOM	POSSIBLE SOLUTION
1. Instrument will not turn on, LCD displays "LO BAT", or Main display flashes "OFF"	<ul style="list-style-type: none"> A. Low battery voltage, replace batteries B. Batteries installed incorrectly, check battery polarity C. Return system for service
2. Instrument will not calibrate.	<ul style="list-style-type: none"> A. Replace membrane and electrolyte B. Clean probe electrodes C. Return system for service
3. Instrument "locks up".	<ul style="list-style-type: none"> A. Remove batteries, wait 15 seconds for reset, replace batteries B. Replace batteries C. Return system for service
4. Instrument readings are inaccurate.	<ul style="list-style-type: none"> A. Verify calibration altitude and salinity settings are correct and recalibrate. B. Probe may not have been in 100% water saturated air during calibration procedure. Moisten sponge in calibration chamber and recalibrate. C. Replace membrane and electrolyte. Recalibrate. D. Clean probe electrodes. E. Return system for service.
5. Main display reads "Over" or "Undr".	<ul style="list-style-type: none"> A. Sample O₂ concentration is more than 60 mg/L or 500%, or less than -0.02 mg/L or -0.3%. B. Verify calibration altitude and salinity settings are correct and recalibrate. C. Replace membrane and electrolyte. Recalibrate. D. Clean probe electrodes. E. Return system for service.
6. Main display reads "Over" or "Undr" during calibration.	<ul style="list-style-type: none"> A. Replace membrane and electrolyte. Recalibrate. B. Clean probe electrodes. C. Return system for service.

SYMPTOM	POSSIBLE SOLUTION
7. Secondary display reads "Ovr" or "Undr".	A. Sample temperature is less than -5° C (23°F) or more than +45°C (122°F). Increase or decrease the sample temperature to bring within the allowable range. B. Return system for service.
8. Main display reads "Err" and Secondary display reads "RO", "RA", or "AdC".	A. Return system for service
9. Main display reads "Err" or "burn" and Secondary display reads "EEP"	A. Return system for service

CONTACT INFORMATION

YSI offers a wide range of customer assistance and technical support functions to ensure that you have the information required to use our products. Contact YSI if you need assistance or have questions regarding any YSI Product. Business hours are Monday through Friday, 8AM to 5PM ET.

YSI Environmental Incorporated
 1725 Brannum Lane
 Yellow Springs, OH 45387
 Toll Free: 800-897-4151 (US)
 Phone: +1 937 767-7241
 Fax: +1 937 767-1058
 E-Mail: environmental@ysi.com
www.ysi.com

REQUIRED NOTICE

The Federal Communications Commission defines this product as a computing device and requires the following notice:

This equipment generates and uses radio frequency energy and if not installed and used properly, may cause interference to radio and television reception. There is no guarantee that interference will not occur in a particular installation. If this equipment does cause interference to radio or television reception, which can be determined by turning the equipment off and on, the user is encouraged to try to correct the interference by one or more of the following measures:

- re-orient the receiving antenna
- relocate the YSI Instrument with respect to the receiver
- move the YSI Instrument away from the receiver
- plug the YSI Instrument into a different outlet so that the computer and receiver are on different branch circuits.

If necessary, the user should consult the dealer or an experienced radio/television technician for additional suggestions. The user may find the following booklet, prepared by the Federal Communications Commission, helpful: "How to Identify and Resolve Radio-TV Interference Problems." This booklet is available from the U.S. Government Printing Office, Washington, DC 20402, Stock No. 0004-000-00345-4.

Note: While testing to EN-61000-4-6, Conducted RF Immunity, per Table A.1 of EN61326, Electrical Equipment for Measurement, Control and Laboratory Use, the YSI 550A exhibited an ERROR 8 message from 8.6 MHz 22.8 MHz at induced RF voltages of 3-Volts to 1-Volt RMS on the 25-foot probe cable. If you observe this interference please relocate the probe-cable away from heavy industrial equipment power and control cables or communications equipment cables which may be causing the interference.